

STORHY FINAL EVENT

HYDROGEN STORAGE SYSTEMS FOR AUTOMOTIVE APPLICATION

PSA POISSY, JUNE 3-4, 2008



Subproject Cryogenic Storage: General Overview

Objectives

- ❖ The state-of-the-art **liquid hydrogen tank** is cylindrically shaped and made of stainless steel. The automotive industry would benefit from **liquid hydrogen tanks with optimized shape and reduced weight**. The main objective of this subproject was to develop such a fuel storage system.
- ❖ Use of **fibre reinforced materials** to meet the demands of new design and weight reduction
- ❖ Development of an adequate **protection (liner) against hydrogen permeation** through the inner tank shell and to **prevent outgassing** of the fibre reinforced composite materials
- ❖ Development and evaluation of **manufacturing processes** suitable for a composite free-form light weight tank

Achievements

- ❖ **Specification** of the cryogenic storage system and definition of the system concept
- ❖ **Design** of a scalable free-form storage system adapted to the vehicle structure as well as cylindrical prototypes
- ❖ **Selection** and subsequently **testing of suitable materials** and appropriate **production processes**
- ❖ **New type of vacuum insulated liquid hydrogen fuel storage systems, made from fibre reinforced composite materials**
- ❖ **Verification tests with gaseous and liquid hydrogen** have been performed with samples and cylindrical prototypes
- ❖ **First liquid hydrogen free-form tank demonstrator worldwide**
- ❖ Higher integration level due to **improved auxiliary system** (incl. innovative cryogenic multi-way valve)
- ❖ Significant **increase of the gravimetric energy density** on system level by factor three compared to state-of-the-art (extrapolated up to **18 wt.%**)

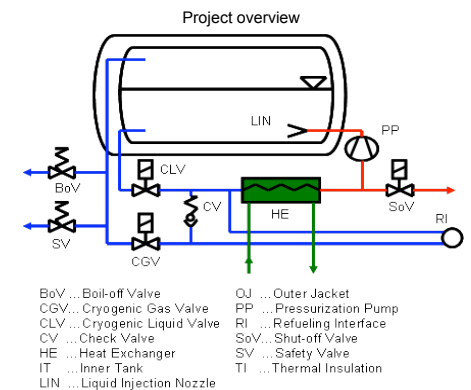
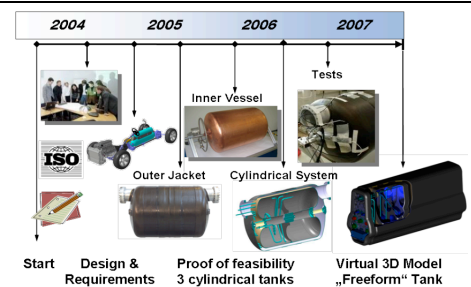

Scheme of liquid hydrogen fuel storage system

Future Perspectives

- ❖ This major step in research of cryogenic containers **paves the way for future developments** of new light weight and vehicle-adapted systems.
- ❖ **Improvement of the thermal insulation** is necessary.
- ❖ **Proof of durability**, increase of **degree of automation** and **reduction of production cycle time**.

Partners	<ul style="list-style-type: none"> ❖ Air Liquide ❖ Austrian Aerospace GmbH ❖ BMW Forschung und Technik GmbH ❖ Institut für Verbundwerkstoffe GmbH ❖ Linde AG ❖ MAGNA STEYR Fahrzeugtechnik AG & Co KG ❖ MT Aerospace AG ❖ Oerlikon Space AG ❖ Prochain e.V. ❖ Volvo Technology Corporation 	

Website www.storhy.net



The project partners wish to thank the European Commission for financial support of the Integrated Project StorHy– Hydrogen Storage Systems for Automotive Application (Contract No.: SES6-CT-2004-502667) within the 6th RTD Framework Programme.