

STORHY FINAL EVENT

HYDROGEN STORAGE SYSTEMS FOR AUTOMOTIVE APPLICATION

PSA POISSY, JUNE 3-4, 2008



Subproject Cryogenic Storage: Outer Jacket Half Shell

Objectives

- ❖ Design and manufacture a cylindrical outer jacket made of light weight composite materials (e.g. carbon fibre reinforced plastic - CFRP)
- ❖ Material selection and manufacturing technology according to the specific requirements of vehicles

Description

Tank parameters:

- ❖ Mass = 8.3 kg (incl. flange)
- ❖ Length 1 = 533.1 mm (incl. flange)
- ❖ Length 2 = 463.8 mm (half shell only)
- ❖ Diameter liner = 604.0 mm
- ❖ Max. diameter = 613.1 mm
- ❖ High vacuum flange type = CF 160
- ❖ Number of composite layers = 6, 8, 14
- ❖ Number of parts = 6 (excl. pipes)
- ❖ Tank wall thickness:
 - Structural liner = 1 - 2 mm
 - Composite layer = 2.4 mm
- ❖ Materials:
 - Structural liner = aluminium
 - Composite material = carbon fibre reinforced plastic (epoxy resin & T700 carbon fibre)
 - Flange = stainless steel & aluminium
 - Insert = aluminium

Main specifications:

- ❖ Mean load = buckling against vacuum
- ❖ Inner pressure = high vacuum
- ❖ Outer pressure = ambient pressure
- ❖ Leak rate = $< 10^{-6}$ mbar l/s
- ❖ Operating temperature = -60 – +85 °C
- ❖ Media compatibility = gas: hydrogen, helium, nitrogen, air

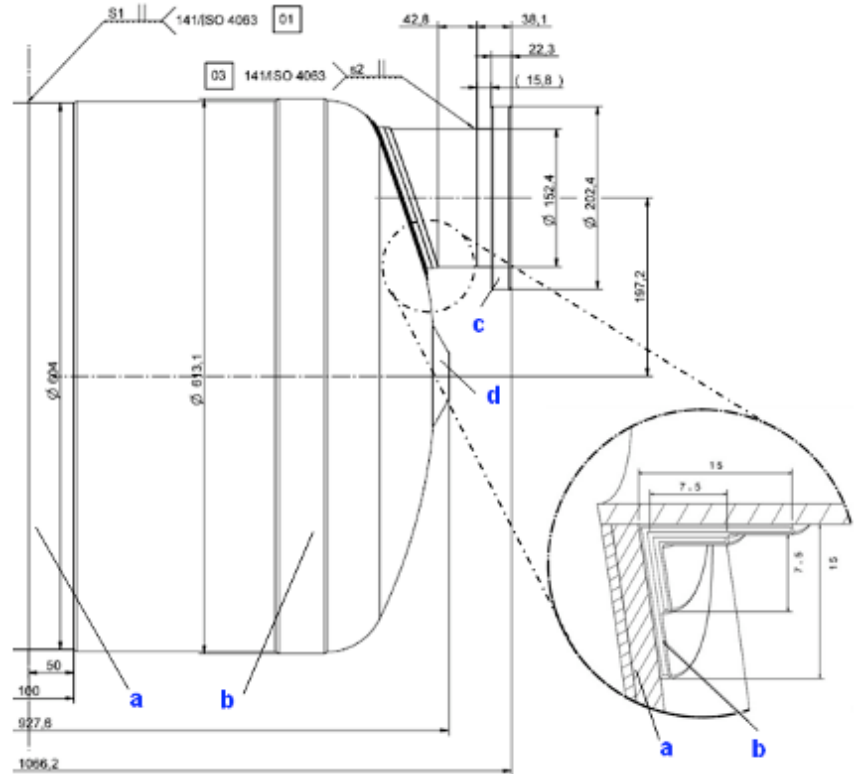

List of parts:

- a = structural liner
- b = composite material layers
- c = flange (for prototype only)
- d = insert for tank support

Future Perspectives

- ❖ Focus on how to industrialize manufacturing process (e.g. assembly of structural liner & composite material).

| | | |
|-----------------|--|--|
| Partners | <ul style="list-style-type: none"> ❖ Air Liquide ❖ Austrian Aerospace GmbH ❖ BMW Forschung und Technik GmbH ❖ Institut für Verbundwerkstoffe GmbH ❖ Linde AG ❖ MAGNA STEYR Fahrzeugtechnik AG & Co KG ❖ MT Aerospace AG ❖ Oerlikon Space AG ❖ Prochain e.V. ❖ Volvo Technology Corporation | |
|-----------------|--|--|

Website www.storhy.net



The project partners wish to thank the European Commission for financial support of the Integrated Project StorHy– Hydrogen Storage Systems for Automotive Application (Contract No.: SES6-CT-2004-502667) within the 6th RTD Framework Programme.