

Subproject Cryogenic Storage: Cryogenic Multi-Way-Valve

Objectives

- ❖ Reduction from 3 separate valves to one single valve
- ❖ Reduction of weight (~ 50 %) compared to state-of-the-art valves
- ❖ Contribute to fulfilling the requirements on costs, quality and safety aspects in a future high volume production

Description

Part description:

- ❖ Type = 5/4 way valve
- ❖ Mass = < 2 kg (incl. actuator)
- ❖ Height = 27 mm
- ❖ Diameter = 66 mm
- ❖ Number of parts = 4 (excl. pipes)
- ❖ Material = mainly stainless steel

Operation sequence:

1. Filling / service
2. All pipes closed = safety position
3. Gaseous hydrogen take-off
4. Liquid hydrogen take-off

Specification:

- ❖ Operating temperature = -253 to +85 °C
- ❖ Max. allowable working pressure = 10 bar
- ❖ Test pressure = 22.5 bar
- ❖ Shut-off pressure = 5.0 bar
- ❖ Filling pressure = 0 to 4 bar
- ❖ Power supply = electrical
- ❖ Max. flow rate (filling) = 55 g/s L-H₂
- ❖ Max. flow rate (extraction) = 6 g/s L-H₂
- ❖ Opening / closing time = < 1 s
- ❖ External hydrogen leakage to atmosphere = $\leq 1 \times 10^{-6}$ mbar l/s
- ❖ External hydrogen leakage to vacuum = $\leq 1 \times 10^{-8}$ mbar l/s
- ❖ Internal leakage = < 1 x 10⁻³ mbar l/s
- ❖ Life time = 20.000 operation cycles

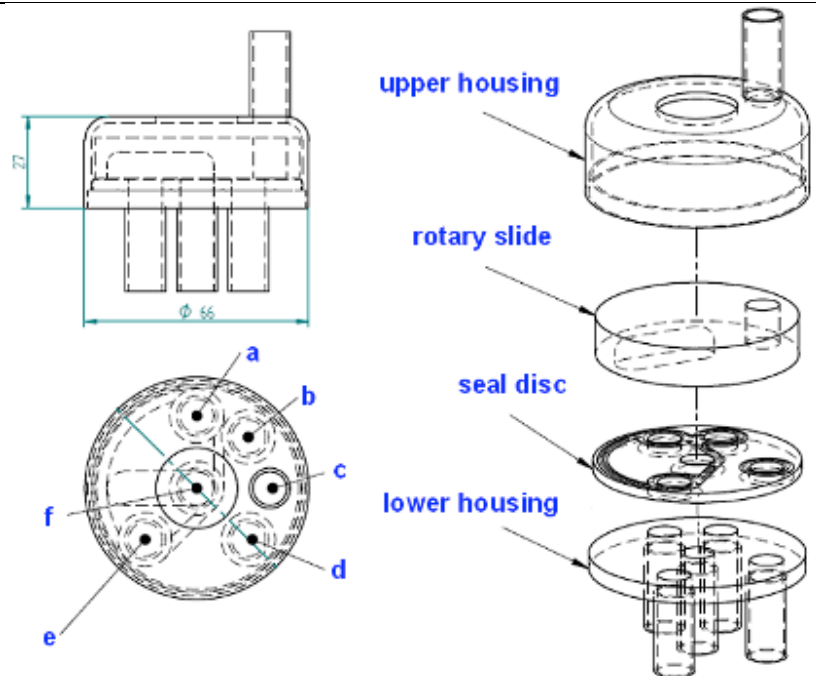

List of parts:

- a = pipe to engine liquid hydrogen
- b = pipe for filling gaseous hydrogen
- c = pipe to tank liquid hydrogen
- d = pipe to engine gaseous hydrogen
- e = pipe for filling liquid hydrogen
- f = pipe to tank gaseous hydrogen

Future Perspectives

- ❖ Lower manufacturing costs and more stable fabrication process thanks to reduced number of parts
- ❖ Integration in projects concerning future liquid hydrogen tank systems.

Partners	<ul style="list-style-type: none"> ❖ Air Liquide ❖ Austrian Aerospace GmbH ❖ BMW Forschung und Technik GmbH ❖ Institut für Verbundwerkstoffe GmbH ❖ Linde AG ❖ MAGNA STEYR Fahrzeugtechnik AG & Co KG ❖ MT Aerospace AG ❖ Oerlikon Space AG ❖ Prochain e.V. ❖ Volvo Technology Corporation ❖ WEKA AG as subcontractor 
-----------------	---

Website www.storhy.net



The project partners wish to thank the European Commission for financial support of the Integrated Project StorHy– Hydrogen Storage Systems for Automotive Application (Contract No.: SES6-CT-2004-502667) within the 6th RTD Framework Programme.